

**ID - F125/150**

# Digimatic Indicator

## User's Manual

Read this User's Manual thoroughly  
Before operating the instrument. After reading,  
retain it close at hand for future reference.

**Mitutoyo**



# CONVENTIONS USED IN USER'S MANUAL

## Safety Precautions

To operate the instrument correctly and safely, Mitutoyo manuals use various safety signs (Signal Words and Safety Alert Symbols) to identify and warn against hazards and potential accidents.

The following signs indicate general warnings:



Indicates a potentially hazardous situation which, if not avoided, could result in serious injury or death.



Indicates a potentially hazardous situation which, if not avoided, may result in minor or moderate injury or property damage.

## On Various Types of Notes

The following types of notes are provided to help the operator obtain reliable measurement data through correct instrument operation.

**IMPORTANT** An important note is a type of note that provides information essential to the completion of a task. You cannot disregard this note to complete the task.  
An important note is a type of precaution, which if neglected could result

**NOTE** A note emphasizes or supplements important points of the main text. A note supplies information that may only apply in special cases (e.g., memory limitations, equipment configurations, or details that apply to specific versions of a program).

**TIP** A tip is a type of note that helps the user apply the techniques and procedures described in the text to their specific needs.  
It also provides reference information associated with the topic being discussed.

Mitutoyo assumes no liability to any party for any loss or damage, direct or indirect, caused by use of this instrument not conforming to this manual.  
Information in this document is subject to change without notice.

**Copyright ©1997-2013 Mitutoyo Corporation All right reserved.**

# Caution on Use

---

## Power Supply Warnings



WARNING

- External power is supplied to the instrument from an AC power source, through an AC adapter. Use only the AC adapters specified by Mitutoyo (No.06AEG302JA, D, E, DC or K/standard accessory).
  - If the instrument is used near a device requiring high voltage, frequency or current, be sure that this device and the instrument's AC adapter have separate power supplies.
  - Use only an AC power supply which conforms to the voltage and frequency written on the AC adapter. Using a voltage or frequency outside the allowed range may result in fire or explosion.
  - When not using the instrument for an extended period, always unplug the AC adapter from the power supply to avoid the risk of fire.
- 

## Other Caution on Use

Observe the following precautions to avoid instrument failure or malfunction.

---



CAUTION

- Do not knock, drop or subject the instrument to excessive force.
  - Do not disassemble or modify the instrument.
  - Do not operate the keys with a pointed instrument (such as a screwdriver).
  - Avoid use or storage of the instrument in direct sunlight, or in extremely hot or cold areas.
  - Use of the instrument in areas of low or high atmospheric pressure may cause instrument failure due to material deterioration.
  - Do not store the instrument in a highly damp or dusty environment. Avoid getting water or oil on the instrument during use.
  - Do not use an electric marking or other high voltage device near the instrument. Electronic parts in the instrument may be damaged. Use in areas where a large amount of electrical noise is present may result in malfunction.
  - Secure the instrument with a dial gage stand or similar fixture in a vibration-free environment.
  - Do not subject the spindle to a vertical load or torsion.
  - To clean the instrument, use a dry soft cloth or cotton swab, or one soaked in diluted neutral detergent. Use of organic solvents (such as thinner or benzene) may result in failure.
  - The contaminated spindle may cause malfunction. Wipe them off with a cloth dampened with alcohol.
- 

To maintain measuring accuracy, take note of the following point.

---

**IMPORTANT**

- In areas of significant temperature fluctuation, thermal expansion of component parts may cause the measured or origin to shift from the set or origin. Use the instrument in a temperature-controlled room with as little temperature fluctuation as possible. Before starting measurement, allow the instrument and the item measured sufficient time to thermally stabilize.
-

## Disposal Warnings

Liquid crystal is used in this product. When disposing of the product, be sure to conform to the local ordinances or regulations in effect in your area.



---

Liquid crystal parts contain a liquid which acts as an irritant. If this liquid accidentally contacts eyes or skin, cleanse the contacted area with clean running water. If taken into the mouth, rinse the mouth immediately and swallow plenty of water. Induce vomiting, then consult a physician.

---

## Warranty

This instrument is manufactured under Mitutoyo's strict quality control system. Should the instrument fail within one year after the date of purchase under normal usage conditions, Mitutoyo will repair it free of charge. Contact your place of purchase or a Mitutoyo sales office.

Mitutoyo will not repair the instrument free of charge in the following cases:

- ◆ If the instrument is damaged or broken due to incorrect operation or unauthorized modifications or repair.
- ◆ If the instrument is damaged or broken due to a drop or shock during moving or shipping after purchase.
- ◆ If the instrument is damaged or broken due to fire, salt damage, toxic gas, abnormal voltage or natural calamity.

This warranty is valid only in the area of purchase.

## WARNING ON EXPORT CONTROL COMPLIANCE

The goods, technologies or software described herein may be subject to National or International, or Japanese Export Controls. To export directly or indirectly such matter without due approval from the appropriate authorities may therefore be a breach of export control regulations and the law.

# Contents

---

<b>CONVENTIONSUSEDINUSER'SMANUAL</b>	<b><i>i</i></b>
SafetyPrecautions	<b><i>i</i></b>
OnVariousTypeofNotes	<b><i>i</i></b>
<b>CautionsonUse</b>	<b><i>ii</i></b>
PowerSupplyWarnings	<b><i>ii</i></b>
OtherCautionsonUse	<b><i>ii</i></b>
DisposalWarnings	<b><i>iii</i></b>
<b>Warranty</b>	<b><i>iii</i></b>
<b>WARNINGONEXPORTCONTROLCOMPLIANCE</b>	<b><i>iii</i></b>
<b>1 NAMEOFPARTS</b>	<b><i>1</i></b>
1.1 MainUnit	<b><i>1</i></b>
1.2 DetailofLCD	<b><i>2</i></b>
<b>2 InstallingtheINSTRUMENT</b>	<b><i>3</i></b>
2.1 SecuringtheInstrumenttoaStandorFixture	<b><i>3</i></b>
2.2 MountingtheLiftingLever	<b><i>3</i></b>
2.3 MountingtheRelease	<b><i>3</i></b>
2.4 MountingtheBack	<b><i>4</i></b>
2.5 ReplacingtheContactPoint	<b><i>4</i></b>
<b>3 BasicOperations</b>	<b><i>5</i></b>
3.1 ConnectingthePowerSource	<b><i>6</i></b>
3.2 Starting/StoppingtheInstrument	<b><i>6</i></b>
3.3 InitialSettings	<b><i>6</i></b>
3.3.1 SwitchingtheInch/Metric	<b><i>6</i></b>
3.3.2 SwitchingtheResolution	<b><i>6</i></b>
3.3.3 SwitchingtheMeasurementSystem	<b><i>6</i></b>
3.3.4 SettingtheOrigin(PRESET)	<b><i>7</i></b>
3.4 MeasurementModes	<b><i>8</i></b>
3.4.1 NormalMode	<b><i>8</i></b>
3.4.2 ToleranceMode	<b><i>8</i></b>
3.4.3 Max.PeakHoldMode	<b><i>9</i></b>
3.4.4 Min.PeakHoldMode	<b><i>9</i></b>
3.4.5 TIR(Run-Out)MeasurementMode	<b><i>9</i></b>

<b>3.5</b>	<b>AnalogDisplay</b>	<b>10</b>
3.5.1	SwitchingtheDisplayRange	10
3.5.2	PointerCentering	10
<b>3.6</b>	<b>SwitchingtheCountingDirection</b>	<b>10</b>
<b>3.7</b>	<b>FunctionLock</b>	<b>10</b>
<b>4</b>	<b>Data/I/O</b>	<b>11</b>
4.1	OutputConnector	11
4.2	OutputDataFormat(DATA1)	11
4.3	TimingChart	12
<b>5</b>	<b>ErrorMessages&amp;CorrectiveMeasures</b>	<b>13</b>
<b>6</b>	<b>Specifications</b>	<b>14</b>
6.1	Specificationsofthemainunit	14
6.2	Standardaccessories	14
6.3	Optionalaccessories	14
6.4	Dimensions	15

# 1 NAME OF PARTS

## 1.1 Main Unit

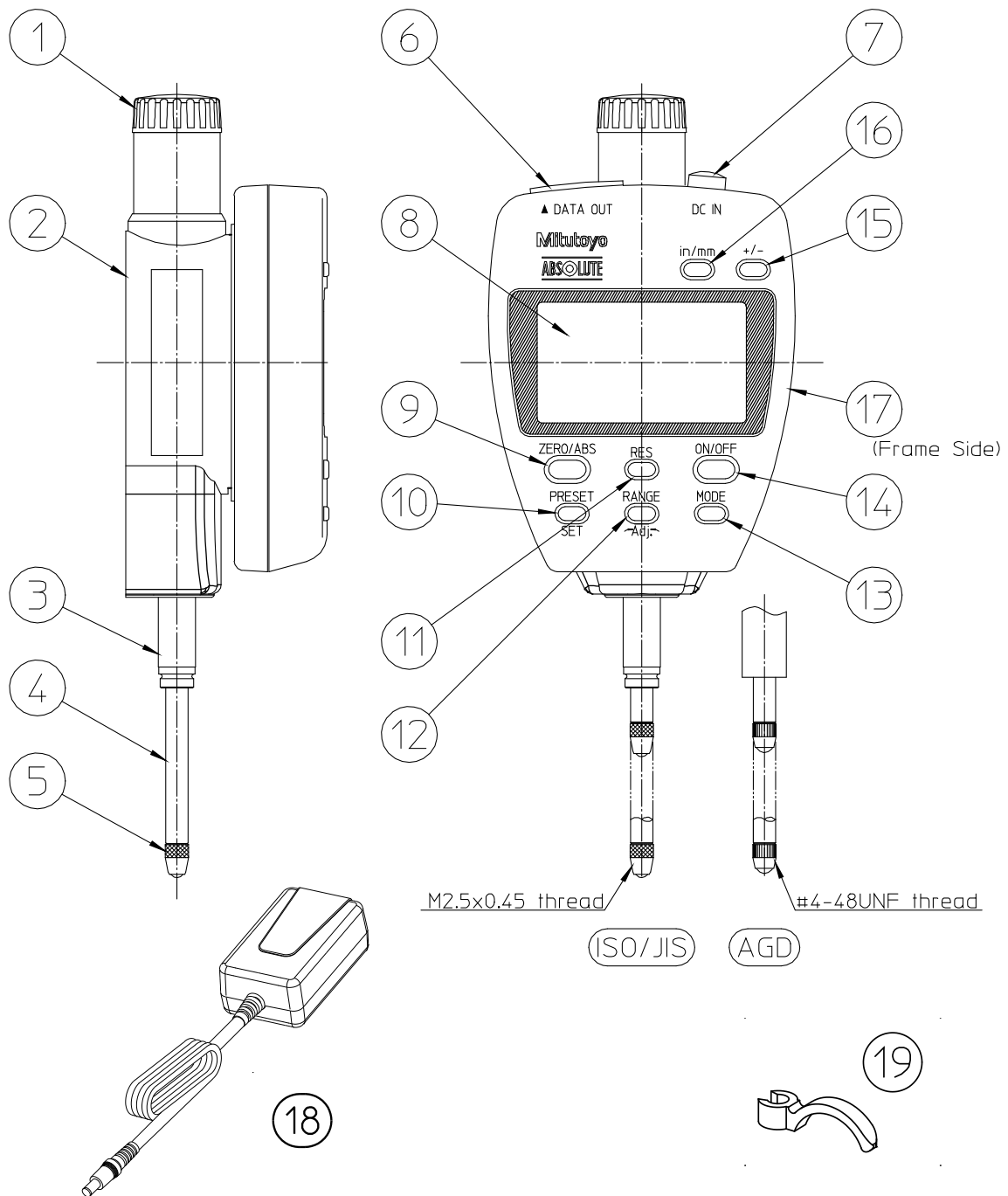

- |                    |                    |                                     |
|--------------------|--------------------|-------------------------------------|
| ① Cap              | ⑧ LCD              | ⑮ +/- key                           |
| ② Flat back        | ⑨ ZERO/ABS key     | ⑯ in/mm key(AGD model)              |
| ③ Stem             | ⑩ PRESET/SET key   | ⑰ Release hole<br>(With Rubber cap) |
| ④ Spindle          | ⑪ RES key          | ⑱ AC adapter                        |
| ⑤ Contact point    | ⑫ RANGE/→Adj.← key | ⑲ Lifting lever                     |
| ⑥ Output connector | ⑬ MODE key         |                                     |
| ⑦ DC jack          | ⑭ ON/OFF key       |                                     |



## 1.2 Detail of LCD

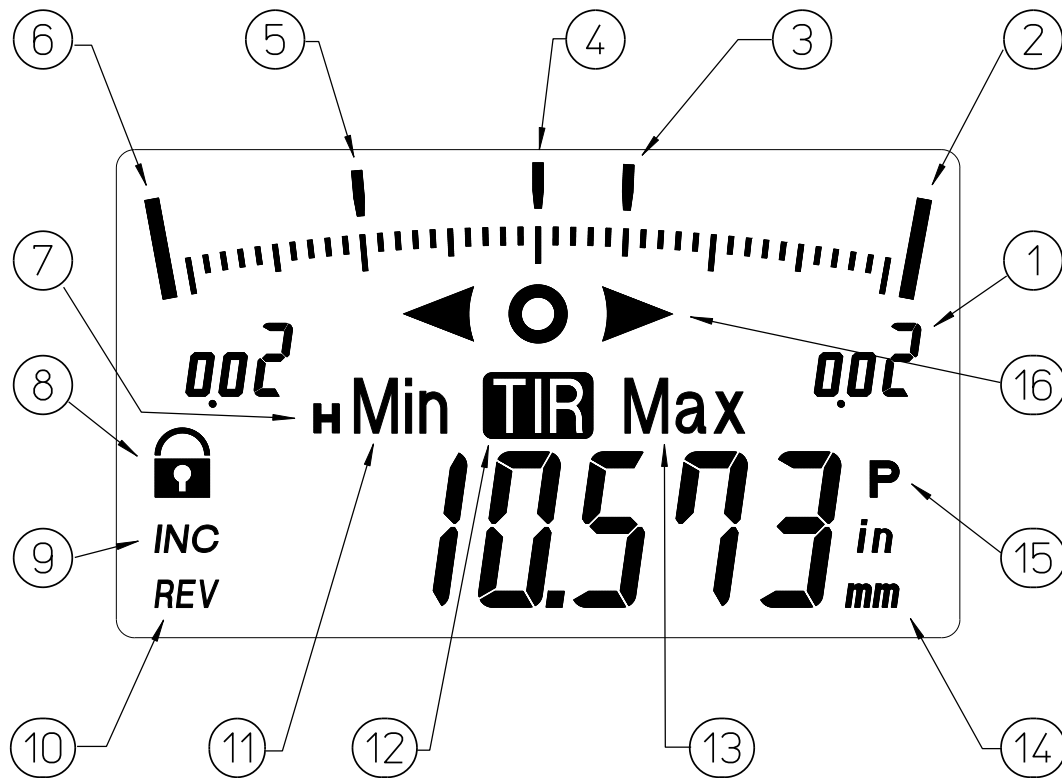

- |                        |                         |                          |
|------------------------|-------------------------|--------------------------|
| ① Analog range         | ⑧ Function lock         | ⑮ Preset the origin      |
| ② Upper over range     | ⑨ Comparison measure    | ⑯ GO/NG judgment display |
| ③ Upper pointer(blink) | ⑩ Reverse count measure |                          |
| ④ Pointer              | ⑪ Min. peak hold mode   |                          |
| ⑤ Lower pointer(blink) | ⑫ TIR mode              |                          |
| ⑥ Lower over range     | ⑬ Max. peak hold mode   |                          |
| ⑦ Hold sign            | ⑭ Unit                  |                          |

•The pointers ③,④and⑤ blink more quickly when two or more overlap.

•The parameters indicated by pointers ③ and ⑤ are determined by the measurement mode, as shown below.

mode	Nomal	Tolerance	Max.peak hold	Min.peak hold	TIR hold
③	(disappear)	Upper limit	Max. point	(disappear)	Max. point
⑤	(disappear)	Lower limit	(disappear)	Min. point	Min. point

## 2 INSTALLING THE INSTRUMENT

### 2.1 Securing the Instrument to a Stand or Fixture

- Secure the instrument by its stem to a dial gage stand (sold separately) or similar fixture.
- When securing the instrument to a fixture, fixing the stem using a slotted holder with an indentation of  $\varnothing 8G7(AGD:\varnothing 9.52)_{+0.005}^{+0.02}$  mm. is recommended.

#### NOTE

- Avoid using a lock screw to fix the stem directly. If it is fixed under a clamping torque of 150cN·m or greater, the spindle may not move smoothly.
- Set up the instrument with the spindle perpendicular to the reference plane or the measured surface. If the spindle axis is not perpendicular to the reference plane (measured surface), measurement errors will result.

#### TIP

For example, if the spindle axis is inclined by an angle  $\phi$  from the perpendicular to the reference plane, for a measured length of about 25 mm and 50mm, the measurement error  $\delta_{25}$ , will be:

$$\phi = 1^\circ : \delta_{25} = 0.004\text{mm}, \quad \phi = 2^\circ : \delta_{25} = 0.015\text{mm}, \quad \phi = 3^\circ : \delta_{25} = 0.034\text{mm}$$

the measurement error  $\delta_{50}$ , will be:

$$\phi = 1^\circ : \delta_{50} = 0.008\text{mm}, \quad \phi = 2^\circ : \delta_{50} = 0.031\text{mm}, \quad \phi = 3^\circ : \delta_{50} = 0.069\text{mm}$$

### 2.2 Mounting the Lifting Lever

- Fit the spindle into the groove on the lifting lever (No. 137693/ standard accessory), holding the spindle's other end so that it doesn't bend.

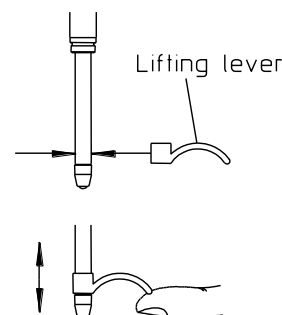

### 2.3 Mounting the Release

- Remove the rubber cap from the release mounting hole, and then insert the release (No.540774/ sold separately) into the hole as deep as possible. (Store the removed rubber cap, taking care not to lose. When attaching the rubber cap, screw it into the hole.)

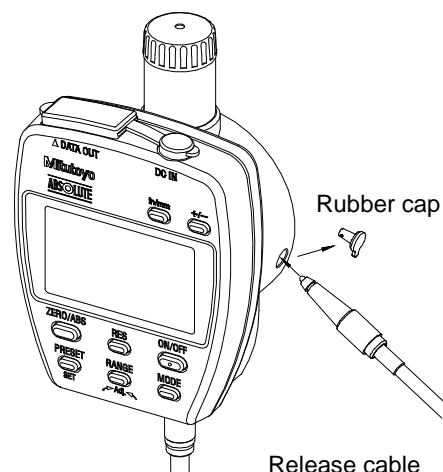

- Pulling sharply on the release or knocking it may strip the thread.
- Inserting objects other than the release into the release hole, or applying excessive force to the hole may cause instrument failure.
- When using the release, the amount of lift is about 25 mm (1"). from the lower limit.

## 2.4 Mounting the Back

The gage can be used with various types of backs for Mitutoyo standard dial indicators (2 series).

- Remove the four screws on top of the back and use them to attach the original back and the optional back.

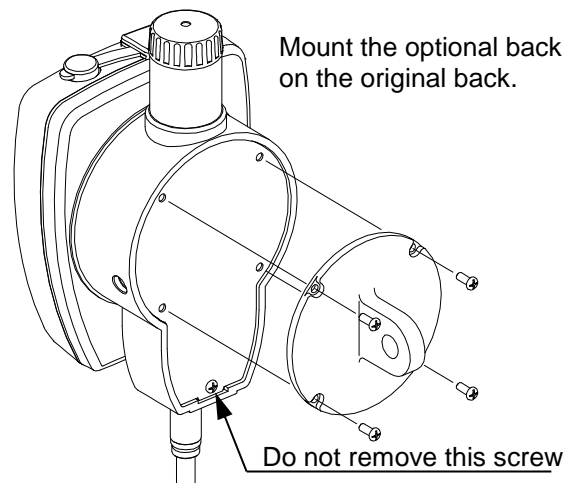

**TIP** Refer to Mitutoyo's general catalog for the lineup of available backs.

## 2.5 Replacing the Contact Point

Various types of interchangeable contact points and extension rods are available for Mitutoyo dial indicators.

- Hold the spindle with a pair of pliers, protecting its surface with a rag.
- Use another pair of pliers to screw in the contact point or remove it.

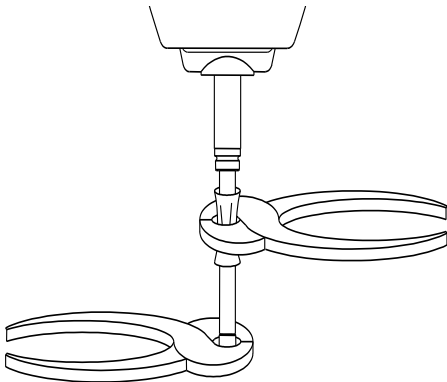

CAUTION

- Hold the spindle in place while doing this procedure, or internal instrument failure may result. Use a rag to protect the spindle's surface. The spindle may not move smoothly if scratched.

**TIP**

- Refer to Mitutoyo's general catalog for the lineup of interchangeable contact points, and extension rods.
- Roller contact point run-out and other contact point errors decrease measurement accuracy.
- Replacing the contact point changes the external dimensions, measuring force and other parameters.
- For questions about replacement parts, contact your place of purchase or Mitutoyo service center.

### 3 BASIC OPERATIONS

Key function list

Key	Condition	Functions	page	
ON/OFF	Anytime	Switching ON⇔OFF	6	
RES	Anytime	Switching 0.001mm⇔0.01mm(.00005"⇔.0005")	6	
ZERO /ABS	Normal Tolerance mode or	<2sec	Switch to the INC system & set to zero	6
		>2sec	Switch to the ABS system	6
	While preset		Cancel preset value & return to the previous condition.	7
	Max, Min hold mode, >2sec	ABS	Set to zero at the hold position	9
INC		Set to zero at the current position	9	
PRESET /SET	Normal mode	Enter the origin setting(Switch to the ABS system)	7	
	While check limit, >2sec	Enter the tolerance limit setting	8	
	except above	Enter the selected mode, release the hold	8	
MODE	Normal mode	Select measurement modes	8	
	except above, >2sec	Return to the normal mode	8	
RANGE/ →Adj.←	<2sec	Switching the analog display range	10	
	>2sec	Pointer centering in analog display's range	10	
+/-	Normal mode, <2sec	Switching the Counting Direction	10	
	Any modes, >2sec	Switching the function lock⇔unlock	10	
in/mm	(AGD model)	Switching inch⇔mm	6	

※ ABS:Absolute measruerment system, INC:Comparative measurement system, >2sec:Press longger than 2sec., <2sec:Short press(less than 2sec.),

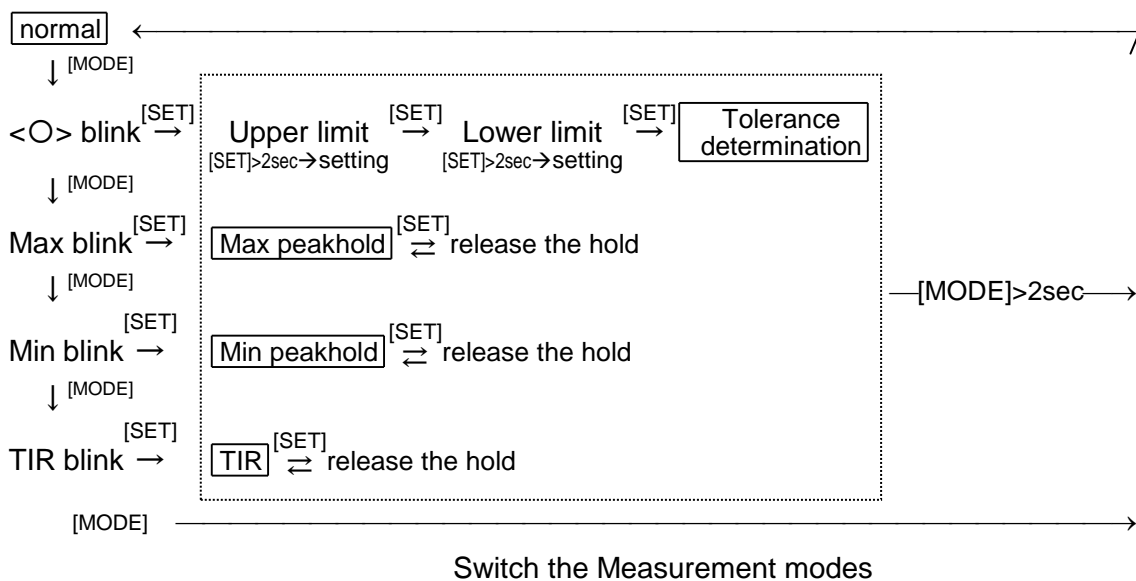

### 3.1 Connecting the Power Source

- Remove the DC jack cover at the top of the instrument's display. Insert the DC plug of the AC adapter (standard accessory) securely into the DC IN jack.
- Insert the AC plug at the other end securely into a power outlet or extension cord.
- As soon as power is supplied, LCD appears and the back light turns on.

**IMPOTANT** •Before shutting off the power supply, always press the [ON/OFF] key to turn the instrument off. Shutting off the power while the instrument is operating can damage origin and other memory data.

### 3.2 Starting/ Stopping the Instrument

- Press the [ON/OFF] key to start(begin) and stop(end) the instrument.

### 3.3 Initial Settings

#### 3.3.1 Switching the Inch/ Metric

- Press the [in/mm] key to toggle the display units between inches↔metric (AGD model).

#### 3.3.2 Switching the Resolution

- Press the [RES] key a short press to toggle the display resolution (between 0.206 mm.↔0.21 mm., for example).

	[RES]<5sec		
	0.001mm	↔	0.01mm
[in/mm]	↕		↕
	0.00005"	↔	0.0005"
[RES] >5sec	↕		↕
	0.0001"	↔	0.001"

Switching the Resolution

- When using inch units, press and hold the [RES] key for 5 seconds or longer in the normal mode to switch the resolution between .00005"↔.0001"(.0005"↔.001") (AGD model only).

**NOTE**

- When the resolution and units are switched, the analog display range also switches.
- The last digit of preset values and tolerance setting values is rounded off according to the number of display digits and units.
- When the display resolution is toggled between .00005"↔.0001"(.0005"↔.001"), set preset values and tolerance values are erased.

#### 3.3.3 Switching the Measurement System

##### 3.3.3.1 Absolute (ABS) Measurement System

When the origin is set in the ABS system, the absolute origin position for measurement is stored in memory. The origin position is held, as long as its position in relation to the absolute origin, or setting value do not change. Measured values are displayed as distances from the absolute origin.

- To switch to the INC system, press the [ZERO/ABS] key in the normal mode or tolerance determination mode. "INC" appears in the LCD and the display is set to zero. (Press and hold the [ZERO/ABS] key again to return to ABS mode).

##### 3.3.3.2Comparative (INC) Measurement System

The INC system holds the position data of the absolute origin, and displays the distance from the position set to zero.

- To switch to the ABS system, press and hold the [ZERO/ABS] key for 2 seconds or longer in the normal mode or tolerance determination mode.

### 3.3.4 Setting the Origin (PRESET)

This section describes how to set the absolute origin for measurement (preset value). You can use a calibrated reference gage or master gage to set a reference plane outside the instrument's measuring range as absolute origin.

- To set the preset value, press [PRESET/SET] key<sup>3</sup> in the normal mode. The previously set preset value appears and "P" blinks in the display.
- The gage is forcibly switched to the ABS system when the origin is preset.
- To set a new preset value, press and hold the [PRESET] key for 2 seconds to select which digit to set. The blinking digit can be set. Give the [PRESET] key a short press to increase the value of the blinking digit.
- While "P" is blinking, give the [PRESET] key a short press to set the new preset value. This value is stored in memory as the distance (origin data) from the absolute origin to the current position of the contact point.

For example, to measure a length which cannot be measured by the instrument alone, as shown in the diagram, set the absolute origin with the bottom end of the master gauge as the measurement reference (0.000 mm.). When the calibration value of the master gauge length is approx. 100.002 mm. and the contact point is contacting the master gauge, set the calibration value to the preset value (origin position setting) by the following procedure.

[PRESET]key	Display value
(set value)	5.432 <sub>mm</sub> <sup>P</sup>
press	+000.000 <sub>mm</sub> <sup>P</sup>
↓ 2sec.	±000.000 <sub>mm</sub> <sup>P</sup>
↓ 2sec.	+000.000 <sub>mm</sub> <sup>P</sup>
release	+000.000 <sub>mm</sub> <sup>P</sup>
short press	+100.000 <sub>mm</sub> <sup>P</sup>
press	+100.000 <sub>mm</sub> <sup>P</sup>
↓ 2sec.	+100.000 <sub>mm</sub> <sup>P</sup>
↓ 2sec.	+100.000 <sub>mm</sub> <sup>P</sup>
↓ 2sec.	+100.000 <sub>mm</sub> <sup>P</sup>
↓ 2sec.	+100.000 <sub>mm</sub> <sup>P</sup>
↓ 2sec.	+100.000 <sub>mm</sub> <sup>P</sup>
release	+100.000 <sub>mm</sub> <sup>P</sup>
short press x2	+100.002 <sub>mm</sub> <sup>P</sup>
press	+100.002 <sub>mm</sub> <sup>P</sup>
↓ 2sec.	+100.002 <sub>mm</sub> <sup>P</sup>
release	+100.002 <sub>mm</sub> <sup>P</sup>
short press (fix)	100.002 <sub>mm</sub>
(repeat value)	99.876 <sub>mm</sub>
press	+100.002 <sub>mm</sub> <sup>P</sup>
short press (fix)	100.002 <sub>mm</sub>

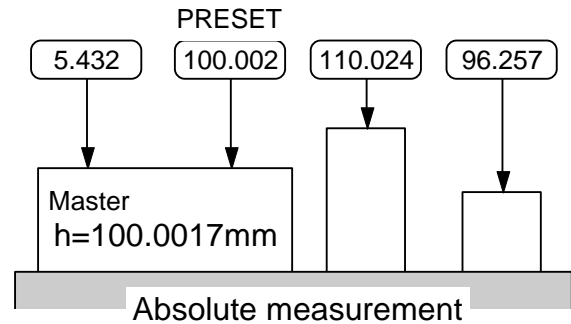

“\_” mean blinking the digit.

#### NOTE

- When setting the origin or the preset value, be sure to lift the spindle at least 0.2mm above the bottom dead center.
- After starting to set the preset value, pressing [ZERO/ABS] before the new preset value has been fixed returns the instrument to the condition it was in before the setting (returns to 99.876 mm. or 5.432 mm. in the above example).
- If the instrument is turned off and on during preset or tolerance setting, the value being set is erased and the gage returns to the condition it was in before setting.

## 3.4 Measurement Modes

The instrument has the five measurement modes described below (see page 5.).

### 3.4.1 Normal Mode





This mode is used for normal measurement, and to select the other modes.

- NOTE**
- 
- To set the origin, switch between + and -, set tolerance limits, or select a new measurement mode, you must return to the normal mode.
- 

### 3.4.2 Tolerance Mode

#### 3.4.2.1 Checking and Setting Tolerance Limits

Tolerance mode is used to check and set the tolerance limits. Note that the tolerance limits must be set separately for the ABS system and the INC system.

- Press the [MODE] key once in the normal mode. "" blinks in the display.
- Press the [PRESET/SET] key to check the tolerance upper limit setting. The previously set upper limit appears with a blinking "" sign.
- To change the upper limit setting, press the [SET] key, and use the same procedure used to set the origin.
- When the new value has been set ("" blinks), press the [SET] key quickly to check the tolerance lower limit setting. The previously set lower limit appears with a blinking "" sign. Change the setting by the same procedure used to change the upper limit setting.
- When both limits have been set correctly, give the [SET] key short press to enter tolerance determination mode.
- Press and hold the [MODE] key for 2 seconds or longer to return to the normal mode from Tolerance mode.

#### 3.4.2.2 Tolerance Determination

If the current measurement value deviates from the range of the tolerance limits set in the previous section, the back lights red as a warning.

- When the tolerance limits have been checked by the procedure in the previous section, the instrument starts tolerance determination straight away.

- NOTE**
- 
- There is no tolerance determination function for max./ min. hold and TIR measurement values.
  - To change the setting of the tolerance limits, first return to the normal mode and then switch to tolerance mode again.
-

### 3.4.3 Max. Peak Hold Mode

In this mode, the instrument holds the maximum value in the series of varying measured values.

- Press the [MODE] key twice in the normal mode. "Max" blinks in the display.
- Press the [PRESET/SET] key to switch to Max hold mode ("Max" stops blinking).
- When the spindle moves, the maximum value is held ("H" appears).
- Press the [SET] key to release the hold, display the current position, and start measuring a new maximum value.
- Press and hold the [MODE] key for 2 seconds or longer to return to the normal mode from Max. Peak Hold mode.

difference of Max,Min,TIR hold mode.

Path	0	→	a	→	b	→	c	→	d
Max mode	0.00	↗	5.00		↗	10.00			
Min mode	0.00		↘		-5.00				
TIR mode	0.00	↗	5.00	↗	10.00	↗	15.00		

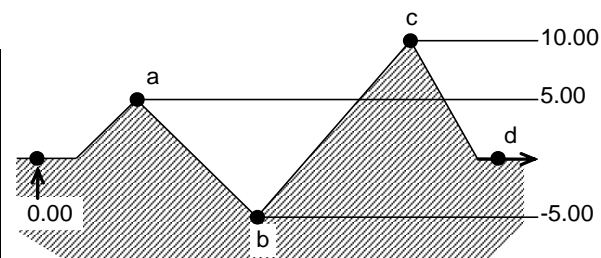

- If max. hold mode is entered from the ABS system, press the [ZERO/ABS] key for 2 seconds or longer to set the position being held to zero. The instrument can be used for comparative measurement.
- If max. hold mode is entered from the INC system, press the [ZERO/ABS] key for 2 seconds or longer to set the current position to zero.

difference of after Zero set (at Max. hold mode)

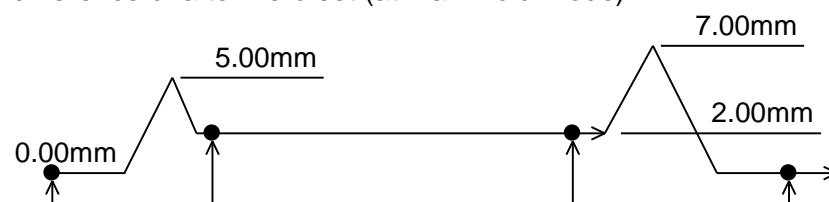

operation	—	—	[ZERO/ABS]>2sec	[PRESET/SET]	
ABS	0.00	<sup>H</sup> 5.00	<sup>H</sup> 0.00	-3.00	<sup>H</sup> 2.00
INC	0.00	<sup>H</sup> 5.00	0.00	0.00	<sup>H</sup> 5.00

### 3.4.4 Min. Peak Hold Mode

In this mode, the instrument holds the minimum value in the series of varying measured values.

- Press the [MODE] key three times in the normal mode. "Min" blinks in the display.
- Min. hold mode operations are done by the same procedure as max. hold mode.

### 3.4.5 TIR (Run-Out) Measurement Mode

In this mode, the instrument holds the run-out width in the series of varying measured values. Only this mode has the same operation in both the ABS and INC systems.

- Press the [MODE] key four times in the normal mode. "TIR" blinks in the display.
- Press the [PRESET/SET] key to set the display to zero ("TIR" appears).
- When the spindle moves, the run-out width is held ("H" appears).
- Press the [SET] key to release the held value and start measuring a new run-out width value.



### 3.5 Analog Display

An analog scale and pointer in the form of dial indicator are continuously displayed at the top of the instrument's LCD. In tolerance determination mode, the limit positions blink in this area. In max./ min. hold mode or TIR mode, the maximum and minimum positions blink in this area.

#### 3.5.1 Switching the Display Range

The analog display range can be switched to prevent pointers going too high or low.

- Press the [RANGE/→Adj.←] key a short press to toggle the display range.

Resolution	Switching the display range(loop)				
0.001mm	0.02(mm)	→0.04	→0.1	→0.2	→0.4
0.01mm	0.2(mm)	→0.4	→1	→2	→4
.00005"	0.001(")	→0.002	→0.004	→0.01	→0.02
.0005"	0.01(")	→0.02	→0.04	→0.1	→0.2
.0001"	0.002(")	→0.004	→0.01	→0.02	→0.04
.001"	0.02(")	→0.04	→0.1	→0.2	→0.4

#### 3.5.2 Pointer Centering

When a pointer is out of the analog display's range, use this function to shift the display so that the pointer is centered. This has the same effect as adjusting the bezel of a dial indicator to the desired scale.

- Press the [RANGE/→Adj.←] key for 2 seconds or longer to center the pointer.

**NOTE** •The pointer position is adjusted so that the current measured value is in the center.

e.g., In case of judgement tolerance for the  $10.000 \pm 0.02$  (Upper & lower limit: 10.020 & 9.980)

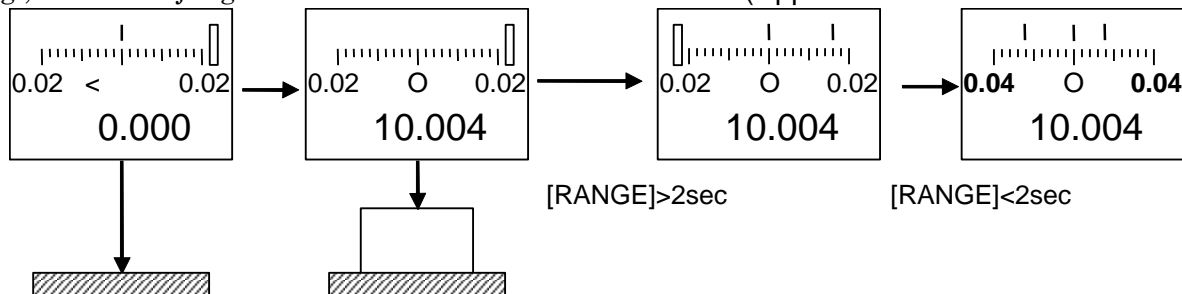

### 3.6 Switching the Counting Direction

By default, the instrument takes the positive direction to be the direction the spindle moves in when it is pushed in. If desired, this direction can be set as the negative direction.

- To reverse the counting direction, press the [+/-] key in the normal mode ("REV" appears).

### 3.7 Function Lock

- Pressing the [+/-] key for 2 seconds or longer deactivates all key input except ON/OFF and hold release (🔒 appears).
- To reactivate the keys, press the [+/-] key again for 2 seconds or longer.

# 4 DATA I/O

Using the Connecting Cable (sold separately), the instrument can be connected to the DP-1 VR Digimatic Mini-processor or similar data processors, to transfer, total and record measurement values.

- Remove the output connector cover and insert the cable securely. (Store the cover in a safe place).

## 4.1 Output Connector

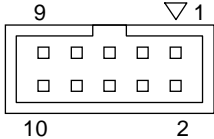

PIN#	Signal	I/O
1.	GND	-
2. *1	DATA1	OUT
3. *1	$\overline{\text{CK}}$	OUT
4.	-	-
5. *2	$\overline{\text{REQ}}$	IN
6.	-	-
7.	-	-
8.	+9V	-
9.	+9V	-
10.	GND	-

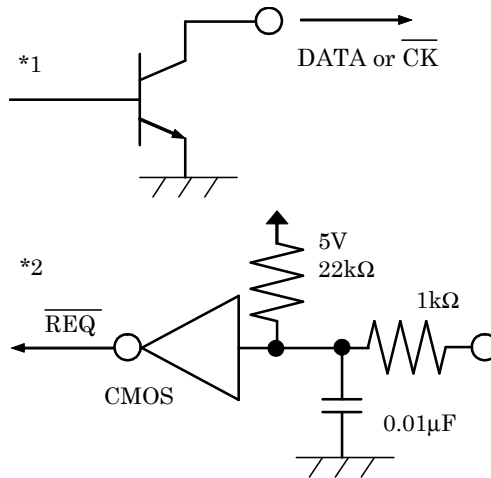

## 4.2 Output Data Format (DATA1)

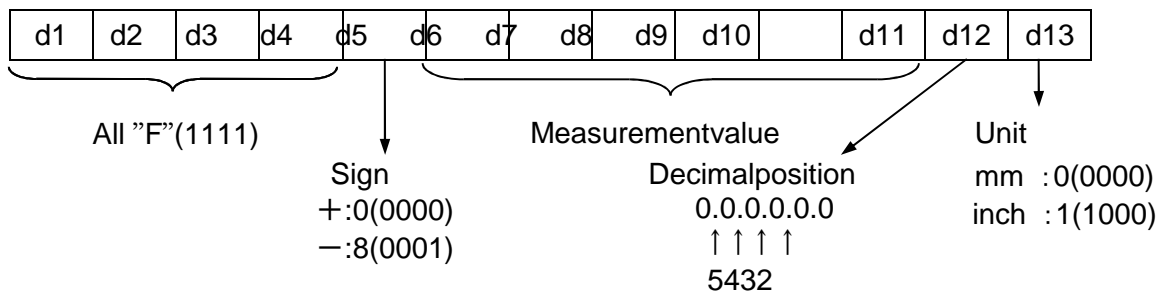

For example., In case of output data as "-2.471mm".

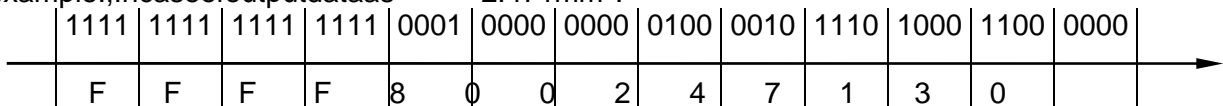

### 4.3 Timing Chart

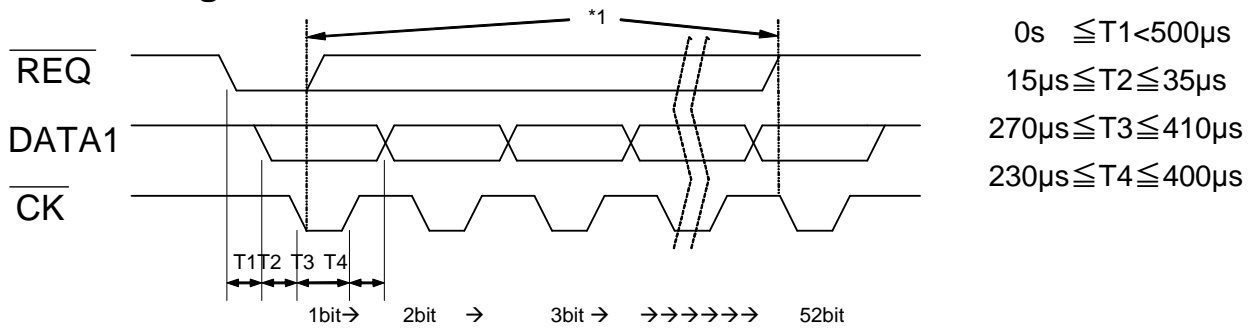

**IMPOTANT**

- Use only the Connecting Cable specified by Mitutoyo or deteriorated cables may result in data output failure.
- Before outputting data, read the manual that comes with the data processor carefully to ensure correct operation.
- Data output may be disabled if an output request (REQ) is received when the spindle is in motion, or if the output request interval is too short.

**CAUTION** \*1: To make an output request (REQ), hold the REQ signal at "Low" until "CK" is output. Return it to "High" before the final (52nd) "CK" bit is output.

## 5 ERROR MESSAGES & CORRECTIVE MEASURES

Display	Description and Corrective measures
<b>XXXXE</b>	<p><b>ABS composition error</b> If this error occurs while the spindle is stopped, it is a malfunction in the internal sensor.</p> <ul style="list-style-type: none"> <li>The instrument requires repair. Contact the Mitutoyo distributor or sales office where you purchased the product.</li> <li>When this error is displayed and soon disappears during spindle movement, this is not the result of an instrument malfunction. This is just an internal processing.</li> </ul>
<b>E--SE</b>	<p><b>Tolerance setting error</b> The tolerance limit value is set with the upper limit value being smaller than the lower limit value.</p> <ul style="list-style-type: none"> <li>Press the Set key to return to tolerance value setting, and then set the values so that the upper limit value is greater than the lower limit value.</li> </ul>
<b>E--SE</b>	<p><b>Upper limit value setting error</b> The upper limit value exceeds the number of digits which can be displayed.</p> <ul style="list-style-type: none"> <li>Press and hold the SET key to return to the upper limit value setting, and then set an appropriate value again.</li> </ul>
<b>E--SE</b>	<p><b>Lower limit value setting error</b> The Lower limit value exceeds the number of digits which can be displayed.</p> <ul style="list-style-type: none"> <li>Press and hold the SET key to return to the lower limit value setting, and then set an appropriate value again.</li> </ul>
<b>E--OF</b>	<p><b>Display overflow</b> The display value exceeds the number of digits which can be displayed.</p> <ul style="list-style-type: none"> <li>During the ABS measurement mode, press the SET key to start measurement origin setting, and then set the preset value again.</li> <li>During the INC measurement mode, press the SET key at an appropriate position to zero set.</li> </ul>

# 6 SPECIFICATIONS

## 6.1 Specificationsofthemainunit

Modelname OrderNo.*1	ID-F125 543-551-1	ID-F150 543-553-1	ID-H150H 543-557-1	ID-F125E 543-552-1	ID-F150E 543-554-1	ID-F150HE 543-558-1
Resolution	0.001mm/0.01mm			0.001/0.01mm/.00005/.0005/.0001/.001"		
Measuringrange	25.4mm	50.8mm		25.4mm=1"	50.8mm=2"	
Accuracy*2 (20°C)	0.003mmorless	0.006mmorless	0.003mmorless	0.003mm/.00012" orless	0.006mm/.00024" orless	0.003mm/.00012" orless
Standards	ISOR463/JISB7503			ANSIB89.1.10/AGD		
Stemdiameter	Ø8mm			Ø9.52mm=3/8"DIA		
Contactpoint	Carbide(M2.5x0.45)			Carbide(#4-48UNF )		
Measuringforce	1.8Norless	2.3Norless		1.8Norless	2.3Norless	
Protectionlevel	EquivalenttoIP30 (IEC60529/JISC0920atfactorydefault)					
Plungerdirection	Belowthehorizon					
Powersupply	ACadapter,9V,500mA					
Operatingtemp.	0°C ~ 40 °C					
Storagetemp.	-10°C ~ 60 °C					
Netweight	Approx220g	Approx290g		Approx.220g (0.49lbs)	Approx.290g (0.64lbs)	

\*1.ThisOrderNo.meanonlythemainunitwithoutA Cadapter.

\*2.Notincludingthequantizingerror( ± 1count).

## 6.2 Standardaccessories

#99MAH001B	User's manual
	Warranty
	WEEEguide
#137693	Liftinglever
#06AEG302JA	ACadapter(100-240V :Japan,USA,Canada,&Co.)
#06AEG302D	ACadapter(100-240V :Germany,&Co.)
#06AEG302E	ACadapter(100-240V :UK,&Co.)
#06AEG302DC	ACadapter(100-240V :ChinaforCCC)
#06AEG302K	ACadapter(100-240V :KoreaforKC)

## 6.3 Optionalaccessories

#540774	Releasecable
#936937	M-SPCable1m
#965014	M-SPCable2m
#02ACA571	Coilspringforupside-downposition(for 125model)
#02ACA773	Coilspringforupside-downposition(for 150model)
	BacksforMitutoyostandarddialgages(2series)
	Interchangeablecontactpointandextensionrodsfor Mitutoyodialgages

## 6.4 Dimensions

- Dimensions shown in the double column are  $\frac{\text{mm}}{\text{inch}}$ , except they are mm.
- This instrument is conform to the standard of the dial indicator in JIS/ISO or ASME/ANSI (AGD), only stem-diameter and contact-point.

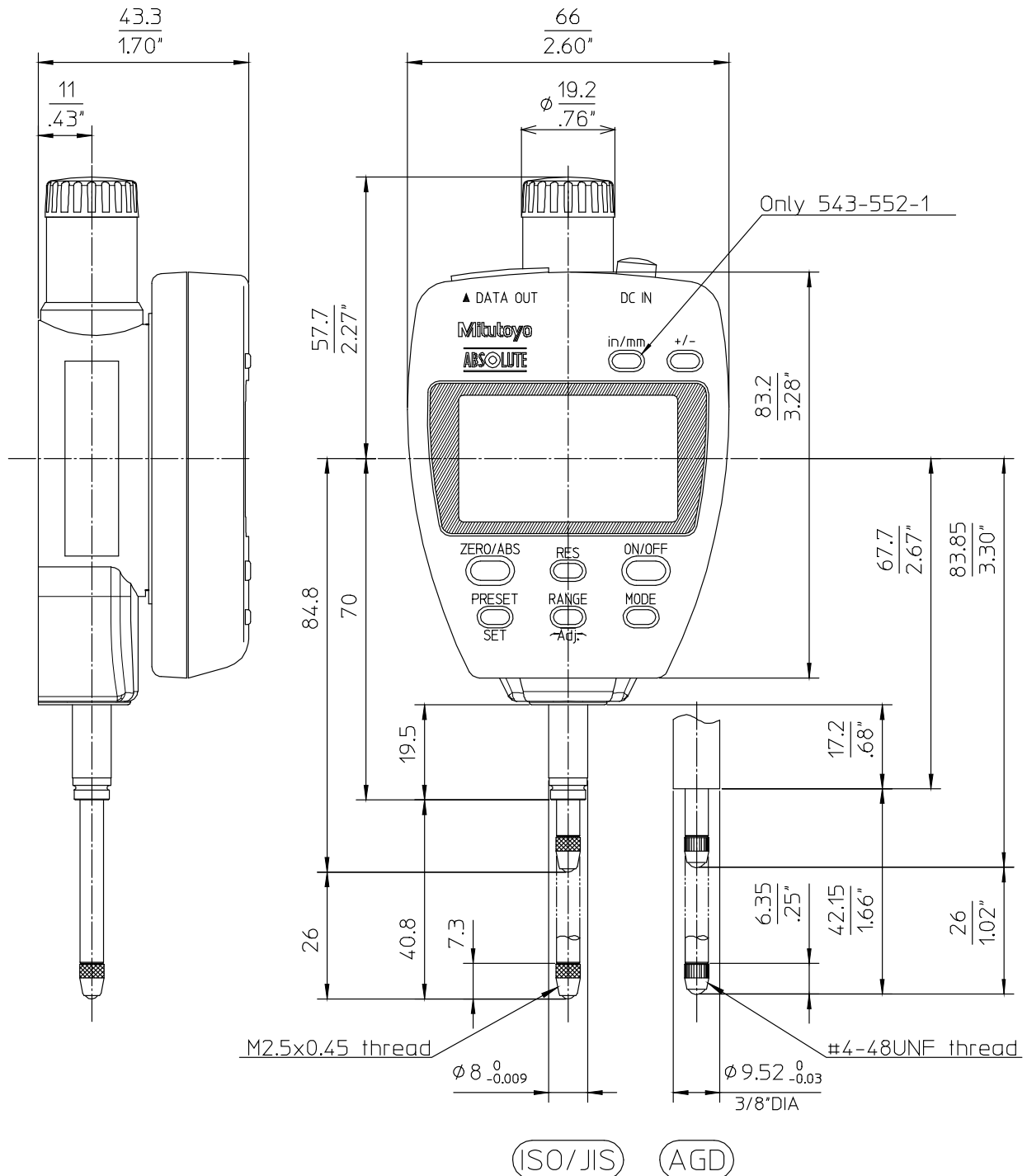

ID-F125 (543-551-1)

ID-F125E(543-552-1)

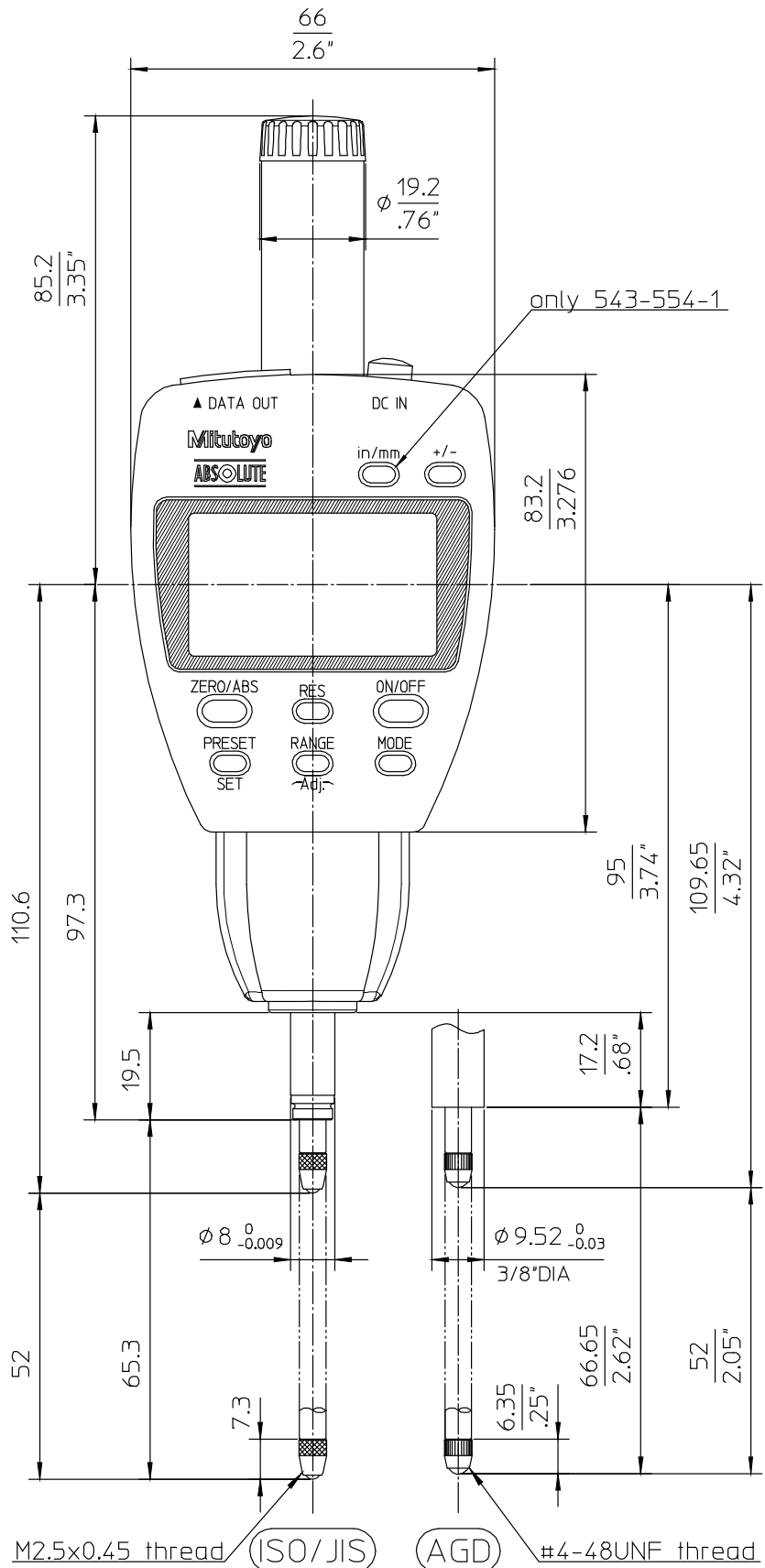
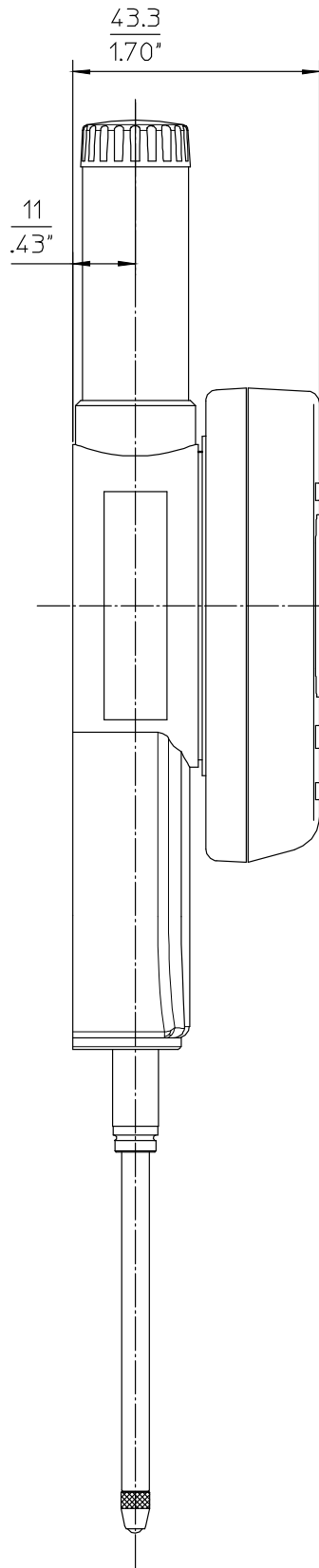

ID-F150	(543-553-1)
ID-F150E	(543-554-1)
ID-F150H	(543-557-1)
ID-F150HE	(543-558-1)





# SERVICE NETWORK

\*As of October 2013

**Chennai Office / M3 Solution Center**  
No. 624, Anna Salai Teynampet, Chennai-600 018, INDIA  
TEL:91(44)2432-8823, 24, 27, 28 FAX:91(44)2432-8825

**Kolkata Office**  
Unit No. 1208,Om Tower, 32,J.L.Nehru Road, Kolkata-700 071, INDIA  
Tel: (91) 33-22267088/40060635 Fax: (91) 33-22266817

**Taiwan**

**Mitutoyo Taiwan Co., Ltd.**  
4F., No.71, Zhouzi St., Neihu Dist.,Taipei City 114, TAIWAN (R.O.C.)  
TEL:886(2)8752-3266 FAX:886(2)8752-3267

**Taichung Branch**  
16F.-3, No.6, Ln.256, Sec.2, Xitun Rd., Xitun Dist., Taichung City 407, TAIWAN (R.O.C.) TEL:886(4)2707-1766 FAX:886(4)2451-8727

**Kaohsiung Branch**  
13F.-3, No.31, Haibian Rd., Lingya Dist., Kaohsiung City 802, TAIWAN (R.O.C.)  
TEL:886(7)334-6168 FAX:886(7)334-6160

**M3 Solution Center Taipei**  
4F., No.71, Zhouzi St., Neihu Dist., Taipei City 114,TAIWAN (R.O.C.)  
TEL:886(2)8752-3266 FAX:886(2)8752-3267

**M3 Solution Center Tainan**  
Rm.309, No.31, Gongye 2nd Rd., Annan Dist., Tainan City 709, TAIWAN (R.O.C.)  
TEL:886(6)384-1577 FAX:886(6)384-1576

**South Korea**

**Mitutoyo Korea Corporation**

**Head Office / M3 Solution Center**  
(Sanbon-Dong, Geumjeong High View Build.), 6F, 153-8, Ls-Ro, Gunpo-Si, Gyeonggi-Do, 435-040 KOREA TEL:82(31)361-4200 FAX:82(31)361-4202

**Busan Office / M3 Solution Center**  
Donghumbuild. 1F, 559-13 Gwaebop-Dong, Sasang-Gu, Busan, 617-809, KOREA  
TEL:82(51)324-0103 FAX:82(51)324-0104

**Daegu Office / M3 Solution Center**  
371-12, Hosan-Dong, Dalseo-Gu, Daegu, 704-230, KOREA  
TEL:82(53)593-5602 FAX:82(53)593-5603

**China**

**Mitutoyo Measuring Instruments (Shanghai) Co., Ltd.**  
12F, Nextage Business Center, No.1111 Pudong South Road, Pudong New District ,Shanghai 200120, CHINA TEL:86(21)5836-0718 FAX:86(21)5836-0717

**Suzhou Office / M3 Solution Center China (Suzhou)**  
No. 46 Baiyu Road, Suzhou 215021, CHINA  
TEL:86(512)6522-1790 FAX:86(512)6251-3420

**Wuhan Office**  
RM. 1206B Wuhan World Trade Tower, No. 686, Jiefang Ave, Jiangnan District, Wuhan 430032, CHINA TEL:86(27)8544-8631 FAX:86(27)8544-8227

**Chengdu Office**  
1-705, New Angle Plaza, 668# Jindong Road, Jinjiang District, Chengdu, Sichuan 610066, CHINA TEL:86(28)8671-8936 FAX:86(28)8671-9086

**Hangzhou Office**  
RM. A+B+C 15/F, TEDA Building, No.256 Jie-fang Nan Road Hexi District,Tianjin 300042, CHINA TEL:86(22)5888-1700 FAX:86(22)5888-1701

**Tianjin Office / M3 Solution Center Tianjin**  
No.16 Heiniucheng-Road, Hexi-District, Tianjin 300210, CHINA  
TEL:86(22)8558-1221 FAX:86(22)8558-1234

**Changchun Office**  
RM.1801, Kaifa Dasha, No. 5188 Ziyou Avenue, Changchun 130013, CHINA  
TEL:86(431)8461-2510 FAX:86(431)8464-4411

**Qingdao Office / M3 Solution Center Qingdao**  
No.135-10, Fuzhou North Road, Shibei District, Qingdao City, Shandong 266034, CHINA TEL:86(532)8066-8887 FAX:86(532)8066-8890

**Xi'an Office**  
RM. 805, Xi'an International Trade Center, No. 196 Xiaozhai East Road, Xi'an, 710061, CHINA TEL:86(29)8538-1380 FAX:86(29)8538-1381

**Dalian Office / M3 Solution Center Dalian**  
RM.1008, Grand Central IFC, No.128 Jin ma Road,Economic Development Zone,Dalian 116600, CHINA TEL:86(411)8718 1212 FAX:86(411)8754-7587

**Zhengzhou Office**  
Room1801,18/F,Unit1,Building No.23, Shangwu Inner Ring Road, Zhengdong New District,Zhengzhou City, Henan Province, 450018,CHINA  
TEL:86(371)6097-6436 FAX:86(371)6097-6981

**Mitutoyo Leepport Metrology (Hong Kong) Limited**  
Rm 818, 8/F, Vanta Industrial Centre, No.21-33, Tai Lin Pai Road, Kwai Chung, NT, Hong Kong TEL:86(852)2992-2088 FAX:86(852)2670-2488

**Mitutoyo Leepport Metrology (Dongguan) Limited / M3 Solution Center Dongguan**  
No.26, Guan Chang Road, Chong Tou Zone, Chang An Town, Dong Guan, 523855 CHINA TEL:86(769)8541 7715 FAX:86(769)-8541 7745

**Mitutoyo Leepport Metrology (Dongguan) Limited – Fuzhou office**  
Rm 2104, City Commercial Centre, No.129 Wu Yi Road N., Fuzhou City, Fujian Province, CHINA TEL (86) 0591 8761 8095 FAX (86) 0591 8761 8096

**Mitutoyo Leepport Metrology (Dongguan) Limited – Changsha office**  
Rm 2121, Dingwang Building, No.88, Section 2, Furong Middle Road, Changsha City, Hunan Province, CHINA TEL (86) 731 8872 8021 FAX (86) 731 8872 8001

**Mitutoyo Measuring Instruments (Suzhou) Co., Ltd.**  
No. 46 Baiyu Road, Suzhou 215021, CHINA  
TEL:86(512)6252-2660 FAX:86(512)6252-2580

## U.S.A.

**Mitutoyo America Corporation**  
965 Corporate Blvd., Aurora, IL 60502, U.S.A.  
TEL:1-(630)820-9666 Toll Free No. 1-888-648-8869 FAX:1-(630)820-2614

**M3 Solution Center-Illinois**  
945 Corporate Blvd., Aurora, IL 60502, U.S.A.

**M3 Solution Center-Ohio**  
6220 Hi-Tek Ct., Mason, OH 45040, U.S.A.  
TEL:1-(513)754-0709 FAX:1-(513)754-0718

**M3 Solution Center-Michigan**  
44768 Helm Street, Plymouth, MI 48170, U.S.A.  
TEL:1-(734)459-2810 FAX:1-(734)459-0455

**M3 Solution Center-California**  
16925 E. Gale Ave., City of Industry, CA 91745, U.S.A.  
TEL:1-(626)961-9661 FAX:1-(626)333-8019

**M3 Solution Center-Massachusetts**  
1 Park Dr., Suite 11, Westford, MA 01886, U.S.A.  
TEL:1-(978)692-8765 FAX:1-(978)692-9729

**M3 Solution Center-North Carolina**  
11515 Vanstory Dr., Suite 150, Huntersville, NC 28078, U.S.A.  
TEL:1-(704)875-8332 FAX:1-(704)875-9273

**M3 Solution Center-Alabama**  
2100 Riverchase Center Suite 106 Hoover, AL 35244, U.S.A  
TEL:1-(205)-988-3705 FAX:1-(205)-988-3423

**CT-Lab Chicago**  
965 Corporate Blvd., Aurora, IL 60502, U.S.A.  
TEL:1-630-820-9666 FAX:1-630-820-2614

**Micro Encoder, Inc.**  
11533 NE 118th St., bldg. M, Kirkland, WA 98034, U.S.A.  
TEL:1-(425)821-3906 FAX:1-(425)821-3228

**Micro Encoder Los Angeles, Inc.**  
16925 E. Gale Ave. City of Industry, CA 91745 USA  
TEL:1-626-961-9661 FAX:1-626-333-8019

**Canada**

**Mitutoyo Canada Inc.**  
2121 Meadowvale Blvd., Mississauga, Ont. L5N 5N1., CANADA  
TEL:1-(905)821-1261 FAX:1-(905)821-4968

**Montreal Office**  
7075 Place Robert-Joncas Suite 129, Montreal, Quebec H4M 2Z2, CANADA  
TEL:1-(514)337-5994 FAX:1-(514)337-4498

**Brazil**

**Mitutoyo Sul Americana Ltda.**  
AV. Joao Carlos da Silva Borges, 1240 - CEP 04726-002 - Santo Amaro - São Paulo - SP, BRASIL TEL:55(11)5643-0000 FAX:55(11)5641-3722

**Regional Office**  
Belo Horizonte - MG  
TEL:55(31)3531-5511 FAX:55(31)3594-4482

**Rio Grande do Sul / PR, SC**  
TEL/FAX:55(51)3342-1498 TEL:55(51)3337-0206

**Rio de Janeiro - RJ**  
TEL:55(21)3333-4899 TEL/FAX:55(21)2401-9958

**Santa Barbara D'Oeste - SP**  
TEL:55(19)3455-2062 FAX:55(19)3454-6103

**Norte, Nordeste, Centro Oeste**  
TEL:55(11)5643-0060 FAX:55(11)5641-9029

**Escritorio BA / SE**  
TEL/FAX:55(71)3326-5232

**Factory(Suzano)**  
Rodovia Indio Tibirica 1555, BAIRRO RAFFO, CEP 08620-000 SUZANO-SP, BRASIL TEL:55(11)4746-5858 FAX:55(11)4746-5936

**Argentina**

**Mitutoyo Sul Americana Ltda.**

**Argentina Branch**  
Av. B. Mitre 891/899 – C.P. (B1603CQD) Vicente López –Pcia. Buenos Aires – Argentina TEL:54(11)4730-1433 FAX:54(11)4730-1411

**Sucursal Cordoba**  
Av. Amadeo Sabattini, 1296, esq. Madrid B° Crisol Sur – CP 5000, Cordoba, ARGENTINA TEL/FAX:54 (351) 456-6251

**Mexico**

**Mitutoyo Mexicana, S. A. de C. V**  
Prolongación Industria Eléctrica No. 15 Parque Industrial Naucalpan Naucalpan de Juárez, Estado de México C.P. 53370, MÉXICO  
TEL: 52 (01-55) 5312-5612, FAX: 52 (01-55) 5312-3380

**M3 Solution Center Monterrey**  
Av. Morones Prieto No 914. Ote., Local 105 - Plaza Malz Col. La Huerta, C.P. 67140 Guadalupe, N.L., México  
TEL: 52 (01-81) 8398-8228, 8398-8227 and 8398-8244 FAX: 52 (01-81) 8398-8226

**M3 Solution Center Tijuana**  
Av. 2o. eje Oriente-Poniente No. 19075 Int. 18 Col. Cd. Industrial Nueva Tijuana C.P. 22500 Tijuana, B. C., México  
TEL: 52 (01-664) 624-3644 and 624-3645 FAX: 52 (01-664) 647-5024

**M3 Solution Center Querétaro**  
Acceso “C” No. 107 Col. Parque Industrial Jurica C.P. 76100 Querétaro, Qro., México  
TEL: 52 (01-442) 340-8018, 340-8019 and 340-8020 FAX: 52 (01-442) 340-8017

**Agascalientes Office / M3 Solution Center**  
Av. Aguascalientes No. 622, Local 12 Centro Comercial El Cilindro Fracc. Pulgas Pandal Norte, C.P. 20138, Aguascalientes, Ags. México  
TEL: 52 (01-449) 174-4140 FAX: 52 (01-449) 174-4143

**Irapuato Office / M3 Solution Center**  
Av. Héroes de Mcozari No. 1655, local A-14 esq. con Boulevard Villas de Irapuato "Plaza Delta" Col. San Miguelito, C.P. 36557 Irapuato. Gto., México  
TEL: 52 (01-462) 144-1200